

MTF0401K5.68				
Property	Symbol	Units	Value	Tolerance
Buss Voltage	Vb	Volts	170	MAX
Max Operating Speed	Sr	RPM	10000	MAX
Peak Torque	Tp	Oz-in	91.2	MAX
Continuous Torque	Tc	Oz-in	29.488	MAX
Torque Constant	Kt	Oz-in/A	15.37	±10%
Friction Torque	Tf	Oz-in	.56	Nom
Damping Torque	Kd	Oi/kRPM	.144	Nom
Peak Current	Ip	A MAX	5.93	MAX
Continuous Current	Ic	A MAX	1.92	MAX
Back EMF Constant	Ke	V/kRPM	12.00	±10%
Terminal Resistance	Rt	Ohms	15.78	±15%
Terminal Inductance	Lt	mH	19.10	±15%
Rotor Inertia	Jr	Oiss	.0003	Nom
Winding Temperature	deg C	deg C	135	MAX
Weight	Wt	Lbs		Nom

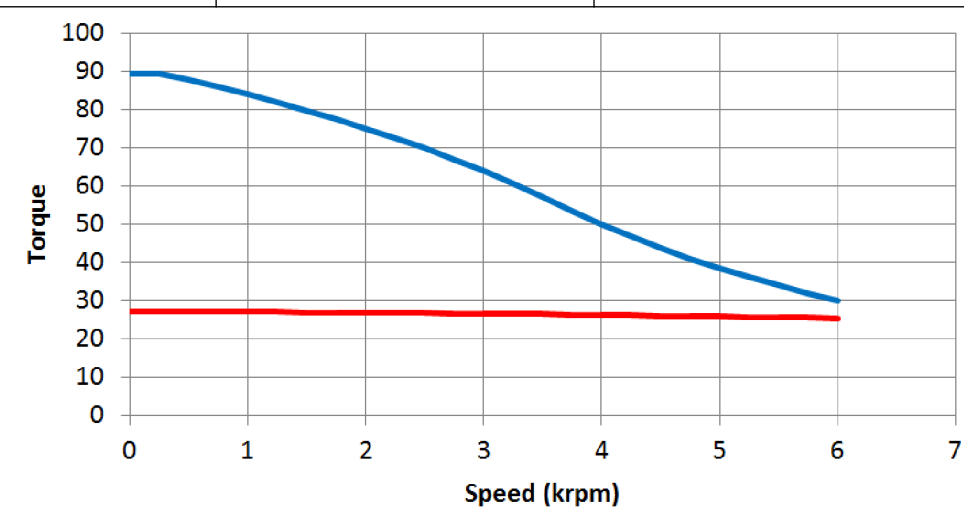
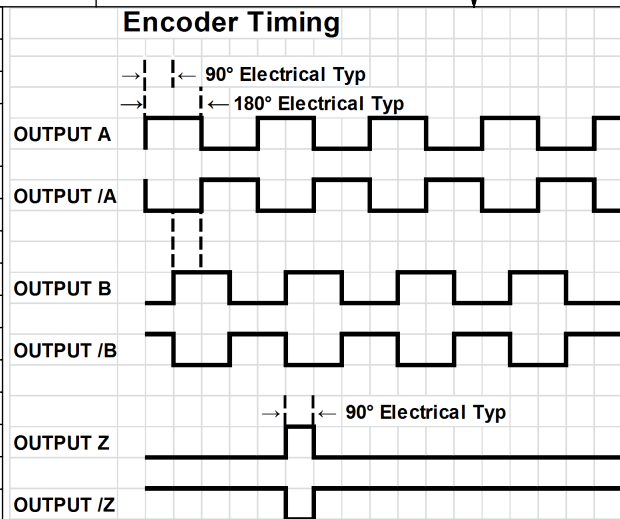

Enc/Comm Cable 28 AWG	
Function	Color
+5v	Red
Gnd	Black
U	Violet
/U*	Gray
V	Wht/Brn
/V*	Wht/Red
W	Wht/Orn
/W*	Wht/Yel
A	Brown
/A	White
B	Blue
/B	Green
Z	Orn
/Z	Yellow
shield	drain

AT 170V BUS AND RATED Tp, Ip

120 Degree Timing Diagram A Style Encoder

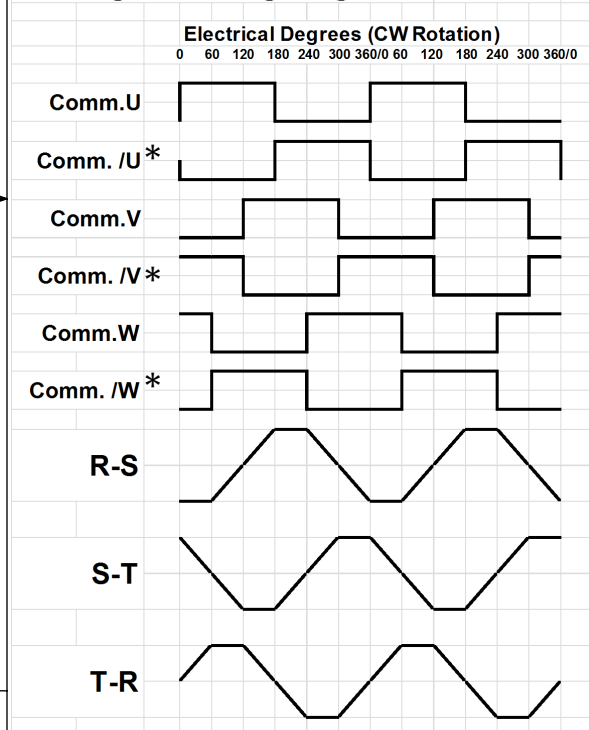

* ONLY IF (A) STYLE ENCODER IS CHOSEN

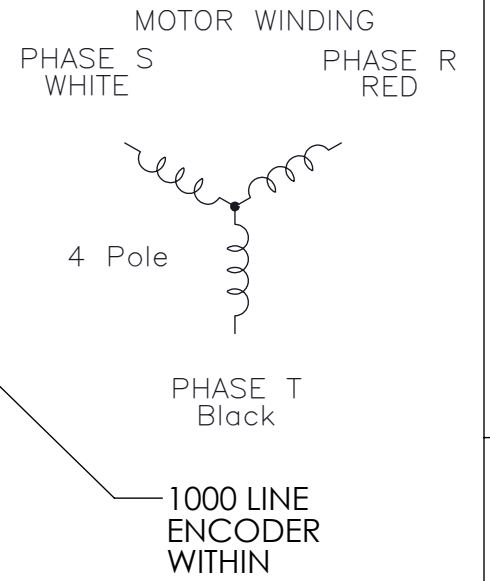
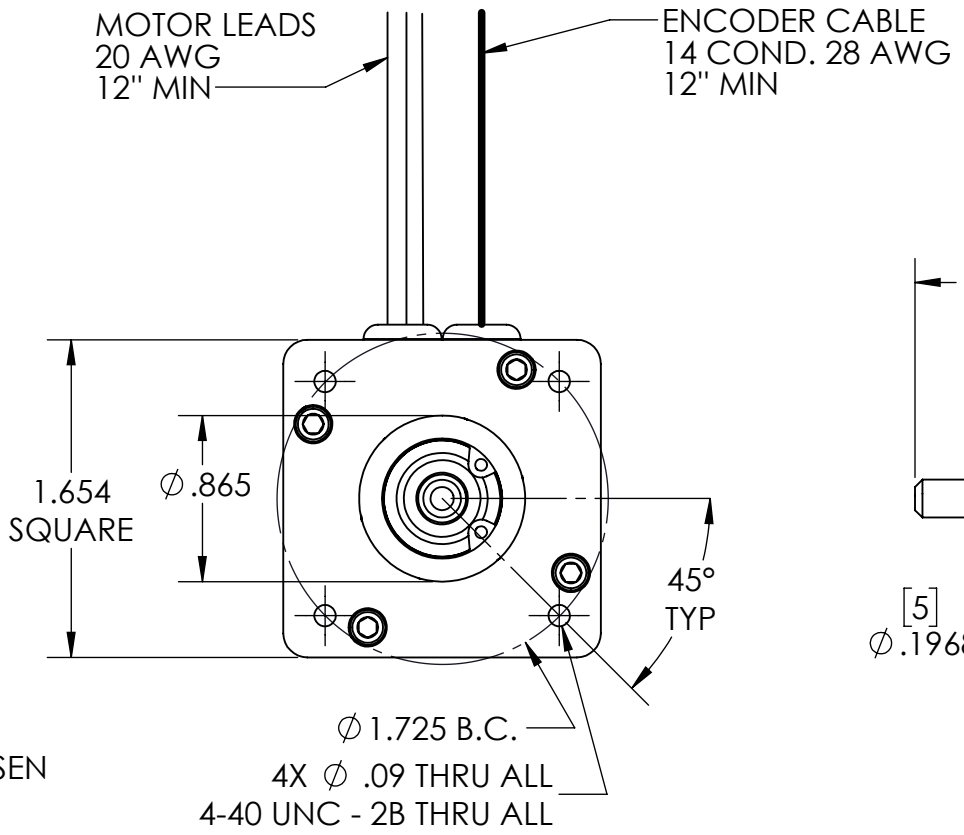

REVISIONS			
DESCRIPTION	REV.	DATE	APP'VD
TO SOLIDWORKS	P1	1/12/2017	

PROPRIETARY AND CONFIDENTIAL

THE INFORMATION CONTAINED IN THIS DRAWING IS CONFIDENTIAL AND THE SOLE PROPERTY OF TRU TECH SPECIALTY MOTORS. ANY REPRODUCTION IN PART OR AS A WHOLE WITHOUT THE WRITTEN PERMISSION OF TRU TECH SPECIALTY MOTORS IS PROHIBITED.

UNLESS OTHERWISE SPECIFIED	
DIMENSIONS: Inches [MILLIMETERS]	
TOLERANCES:	
LINEAR X.XX: ±.01 [.25]	
LINEAR X.XXX: ±.005 [.13]	
ANGULAR: ± 1/2°	
MATERIAL	
FINISH	
PROJECT	FastTrack
STATUS	ACTIVE

TruTech Specialty Motors

SIZE: **B** TITLE: HSF0404K12.0-E1000B

DATE	SIGNATURE	PART NUMBER:	P1
1/11/2017	JAL	53-0385	REV
DRAWN	CHK'D	APP'VD	

SCALE: 1:1 SHEET 1 OF 1